

T. F. RANDOLPH.
Surveying-Instrument.
No. 216,759. Patented June 24, 1879.

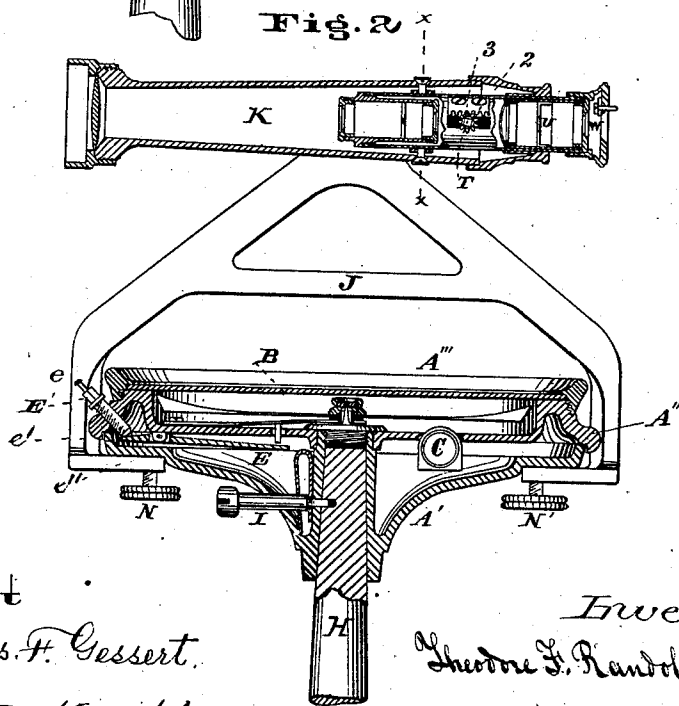
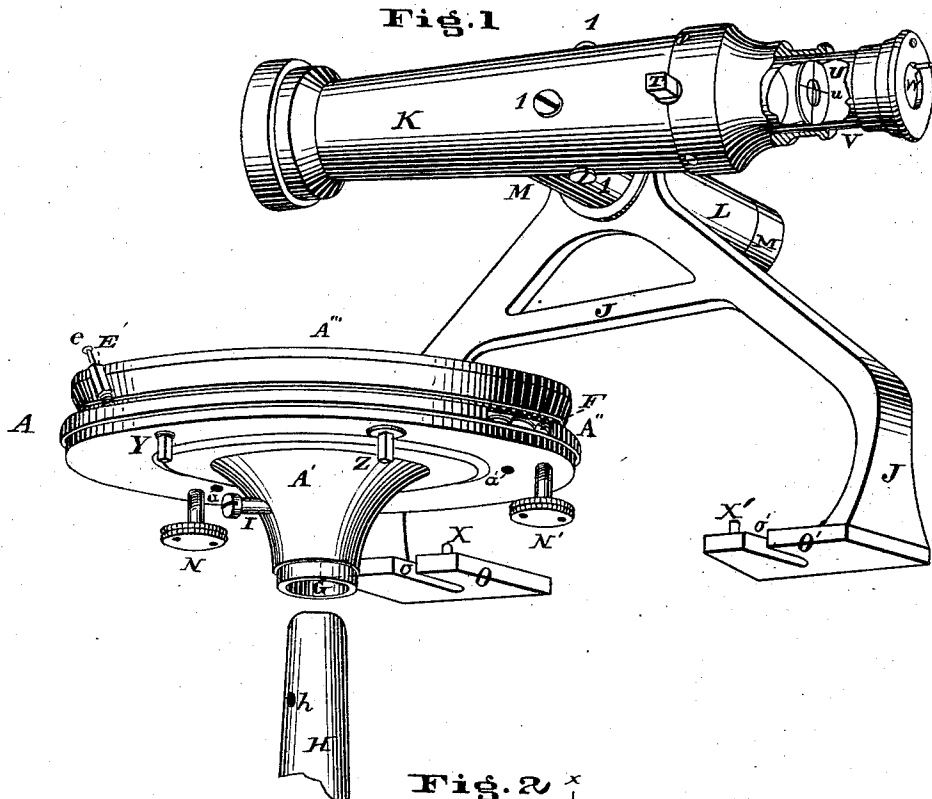

Attest
Chas. F. Gessert.
Walter Knight

Inventor:
Theodore F. Randolph
Walter Knight & Co., Attys.

T. F. RANDOLPH.
Surveying-Instrument.
No. 216,759. Patented June 24, 1879.

Fig. 3

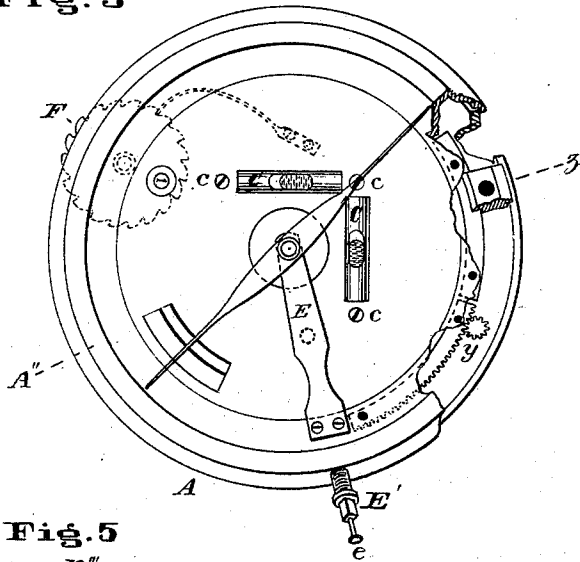

Fig. 4

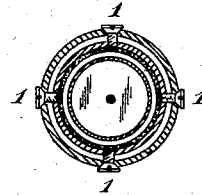

Fig. 5

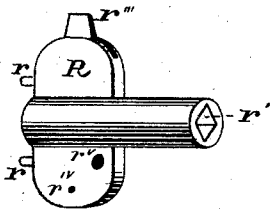

Fig. 6

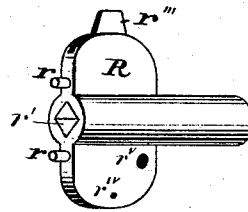

Fig. 7

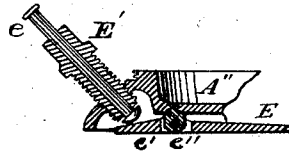
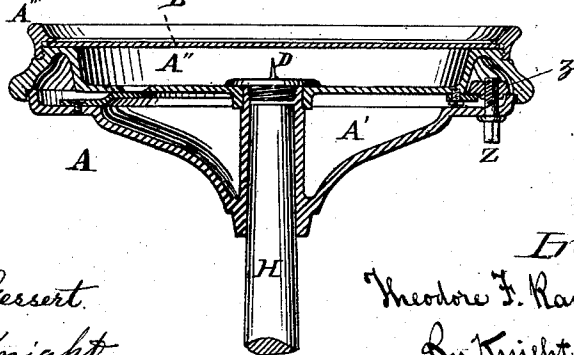

Fig. 8



Attest
Chas. F. Gessert.
Walter Knight

Inventor:
Theodore F. Randolph
By Knight Bros. Attys.

UNITED STATES PATENT OFFICE.

THEODORE F. RANDOLPH, OF CINCINNATI, OHIO.

IMPROVEMENT IN SURVEYING-INSTRUMENTS.

Specification forming part of Letters Patent No. 216,759, dated June 24, 1879; application filed September 2, 1878.

To all whom it may concern:

Be it known that I, THEODORE F. RANDOLPH, of Cincinnati, Hamilton county, Ohio, have invented a new and useful Surveyor's Compass, of which the following is a specification.

This is an improvement in those compasses or field-instruments used by engineers and surveyors, in which a telescope is mounted by suitable trunnions in the vertical plane of the principal axis of the magnetic needle, and above the same; and my improvements are devised for the purpose of bringing the essential members of such instrument within more compact dimensions, and at a cost but little exceeding that of the common sight compass.

The above objects I attain by devices which enable the easy separation of the telescope part from the needle-case, and the latter from its staff or tripod.

In the accompanying drawings, Figure 1 is a perspective view of a field-instrument embodying my improvements, the body or needle-case being shown detached from both the telescope and the ground-staff. Fig. 2 is an axial section of the instrument in the plane of the needle-lifter. Fig. 3 is a top view of the needle-case, portions of the latter being broken away. Fig. 4 is a transverse section of the telescope at the line *xx* of Fig. 2. Figs. 5 and 6 are full-sized representations of my key. Fig. 7 is a vertical section through the needle-lifter. Fig. 8 is an axial section through the needle-case in the plane of the clamp.

The body or needle-case *A* may comprise a customary socket-plate, *A'*, dial-plate *A''*, bezel *A'''*, and the usual glass pane or guard *B*. The dial-face may have the usual cardinal lines, graduated circle, and vernier scale, also the customary levels *C*, and magnetic needle, with a suitable needle-lifter, *E*. The levels may be adjusted to true horizontality by set-screws *c* in the face of the dial. The out keeper-disk may have a notched margin, accessible through an opening in the case, as at *F*. The plate *A'* may have a tapering socket, *G*, for a "Jacob's staff," *H*, having an orifice, *h*, to receive a spring-catch bolt, *I*.

Y represents the square head or arbor of a pinion, which gears in a circular rack of the

dial-plate, as at *y*, for adjustment of the latter to the magnetic meridian. *Z* represents a similar arbor of clamp *z*, by which the dial-plate is held to its adjusted place upon the vernier.

The needle-lifter screw *E'* may be perforated axially to hold a small piston or sliding pin, *e*, whereby the needle-lifter may be brought into momentary action for the purpose of checking the oscillations of the needle.

The needle-lifter proper consists of a spring, *e'*, which, acting through the same lever, *e''*, which transmits the motion of the screw *E'*, operates to instantly retract the piston *e* on the withdrawal of the hand of the operator. This piston appendage to the permanent lifter affords a means for temporarily checking the oscillations of the needle without necessitating any additional perforation in the casing.

The standard or pedestal *J* of the telescope *K* is so attached to the needle-case as to be readily separable therefrom. For this purpose said standard is provided with two downwardly-diverging limbs, as represented, which terminate in feet *O O'*, having slots *o o'* for the reception of thumb-screws *N N'*, which screw into the under side of the plate *A'*. Dowels or steady-pins *X*, projecting upward from the feet *O O'* and entering sockets *a a'* in the plate *A'*, insure the proper location of the standard—that is to say, such as will bring the optical axis in the plane of the vertical axis and the zero-point of the magnetic variation vernier without special care or attention of the user.

Projecting from the standard *J* at right angles to the last-mentioned plane is the bearing or socket *L* for the telescope neck or trunnion *M*.

The principal tube *K* and the trunnion *M* of the telescope constitute integral parts of one casting, preferably of brass.

The cross-wires *u*, instead of being located in the body or principal tube, and requiring special adjustment therein, are attached to an annulus or diaphragm, *U*, secured within the tube *V* of the eye-piece at the exact focus of the eye-lens *W*.

Y represents the square-headed arbor of a pinion, *y*, which gears in the customary circular rack of the dial-plate *A''*. *Z* represents

the similar arbor of clamp *z*, by which the dial-plate is secured to its adjusted place upon the vernier.

I represents four screws, by means of which the eye-piece is collimated to the optical axis.

T is a square-headed arbor, terminating interiorly in a pinion, 2, which, gearing in a rack, 3, upon the eye-piece, enables the latter to be adjusted to focus.

I provide a key or wrench, R, to enable the user to operate the various square-headed arbors, which, for the sake of economy and compactness, take the place, in my improvement, of the customary milled heads. This key is provided with studs *r* to enable the user to loosen or tighten the screws N N', and with sockets *r'* *r''* for the several square-headed arbors E', Y, Z, and T, and a blade, *r'''*, for operating the various nicked screws, such as 1 and *c*, while orifices *r^{iv}* and *r^v* enable the straightening of such parts as the needle-point D and piston *e*.

I claim as new and of my invention—

1. The described separable telescope-standard J, whose feet O O' have steadying-pins X X', which enter sockets *a a'* in plate A', and slots *o o'* for thumb-screws N N', or their equivalents, all combined and operating substantially as set forth.

2. A needle-lifting screw inclosing a self-retracting piston, *e*, as and for the purpose set forth.

3. The out-keeper F, located in the main dial-plate, and having the notched margin, operated through an opening in the dial-case, substantially as set forth.

In testimony of which invention I hereunto set my hand.

THEODORE F. RANDOLPH.

Attest:

GEO. H. KNIGHT,
W. T. JUDKINS.